

### COMPONENTI / COMPONENTS

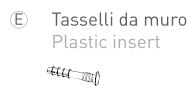

- \* - Guida corta (50 cm) per montanti da 57 - 96 cm
- Short support (50 cm) for uprights from 57 - 96 cm
- Guida lunga (132 cm) per montanti da 146 - 198 - 249 cm
- Long support (132 cm) for uprights from 146 - 198 - 249 cm

### COSA HAI BISOGNO / REQUIRED TOOLS

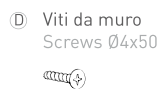
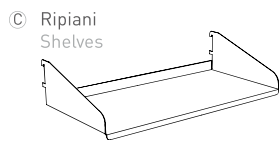
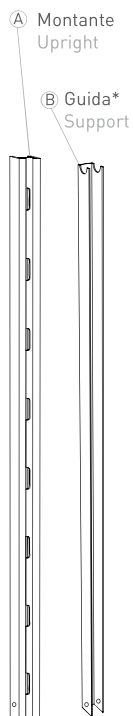
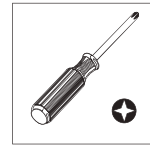
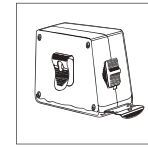
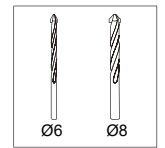
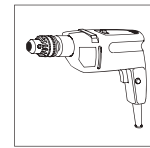
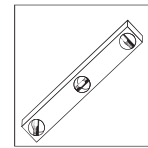

**1** Individuare la posizione in cui si desidera montare la libreria (fig. 1.1). Nel calcolo dell'ingombro totale, bisogna considerare la larghezza dei ripiani (40/60/75.5/90 cm) e la sporgenza dei due montanti esterni 1 cm cad.no. La distanza minima tra i montanti esterni e il bordo del muro, spigolo o angolo deve essere sempre di almeno 3 cm (fig. 1.2). Accostare il montante al muro e segnare con la matita un riferimento all'altezza cui si desidera montare la struttura; quindi spostare il montante dal muro e segnare con la matita un secondo riferimento a 3 cm sotto il primo punto. Forare il secondo punto utilizzando prima la punta da  $\varnothing 6$  mm e successivamente quella da  $\varnothing 8$  mm, per allargare il foro (fig. 1.3).

Browse to the location where you want to install the library (Pic. 1.1). In calculating total footprint, we must considering the width of the shelves (40/60/75.5/90 cm and the projection of the two outer uprights cad.no 1.5 cm). The minimum distance between the uprights and the outer edge of the wall, corner or angle must always be at least 4 cm (Pic. 1.2). Pull the mast to the wall and mark with a pencil a reference height at which you want to mount the structure, then move the pillar from the wall and mark with a pencil a second reference to 3.5 cm below the first point. Drill the second point first using the drill  $\varnothing 4$  mm to 8 mm and then that, in order to enlarge the hole (Pic 1.3).

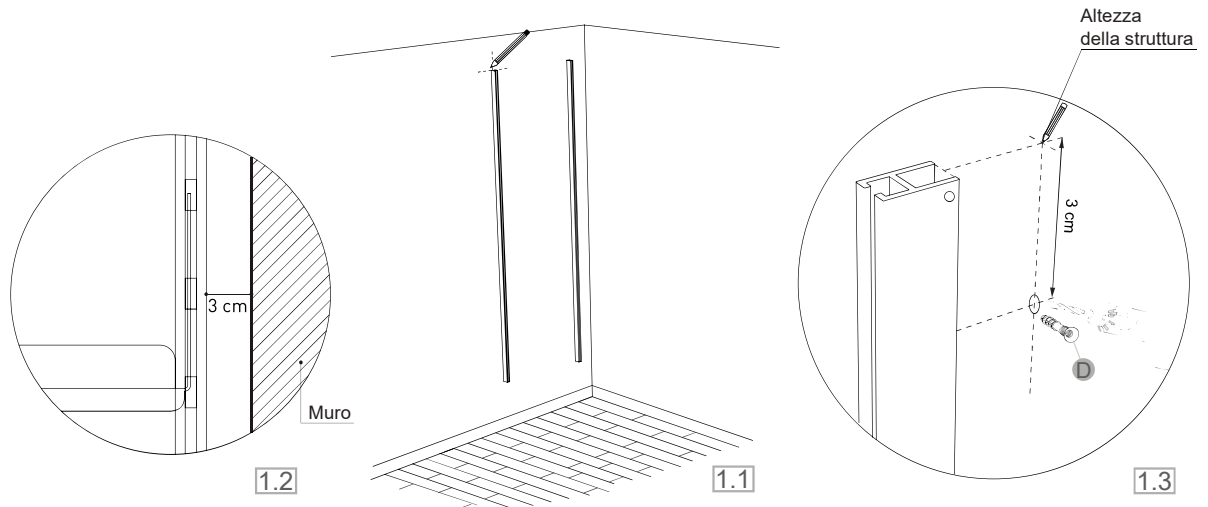

**2** Porre la dima in corrispondenza del primo foro (2.1) e segnare il successivo a 40, o 60, o 75.5, o 90 cm in base alla larghezza del ripiano, utilizzando la livella, verificare che i due fori siano allineati tra di loro. Place the template in correspondence of the first hole (2.1) and the next mark to 40, or 60, or 75.5, or 90 cm to the width of the shelf, using the level ensure that the two holes are aligned with each other.

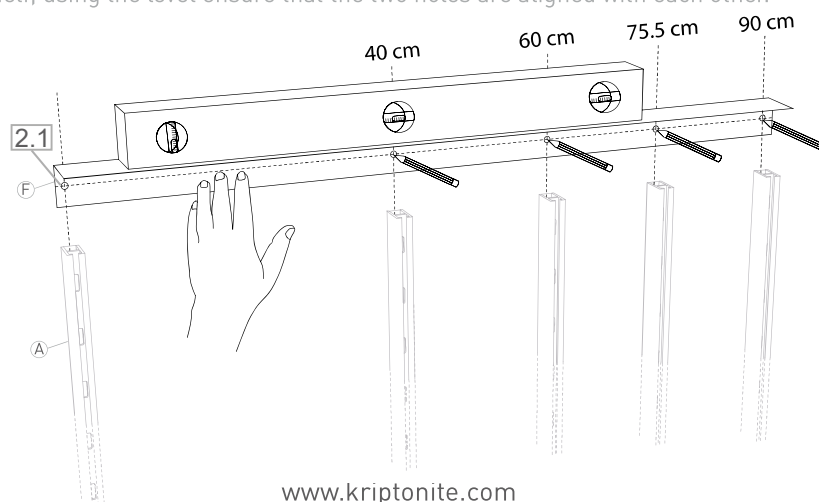

- 3** Fissare la guida con viti e tassello in corrispondenza del primo foro, e segnare i riferimenti per quelli sottostanti (fig. 3.1).  
 Forare i rimanenti fori ed inserire il tassello (fig. 3.2). Bloccare la guida con le viti in dotazione (fig. 3.3).  
 Terminato il fissaggio dei fori, agganciare il montante alla guida (fig. 3.4). Nel caso di pareti non a piombo utilizzare i distanziali per compensare i dislivelli.
- Secure the rail with screws and dowels at the first hole, and mark the references to those below (3.1).  
 Drill the remaining holes and insert the tassello (3.2). Hold the guide with the supplied screws (3.3).  
 Finished fixing holes, hook the mast to the guide (3.4). Use spacer rings in case of non perpendicular walls.

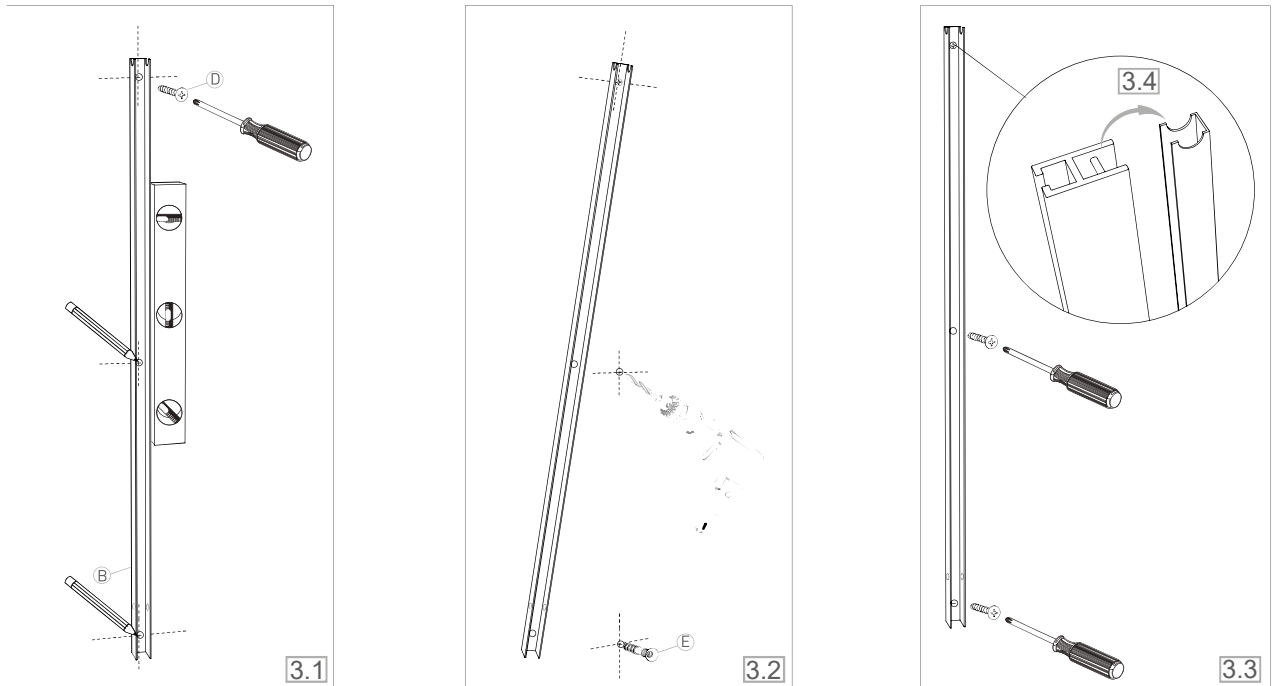

- 4** Ripetere i passaggi 2 e 3 per il fissaggio del secondo montante. Prima di procedere con il resto delle campate, inserire due ripiani (vedi passaggio 5) alle estremità della campata per verificarne il corretto assetto (fig. 4.1). Ricordiamo inoltre che le alette del ripiano dovranno occupare non oltre metà foro del montante (fig. 4.2). A questo punto sarà possibile procedere con le restanti campate ripetendo i passaggi 2, 3 e 4.
- Repeat steps 2 and 3 for the fixing of the second upright. Before proceeding with the rest of the bays, insert two shelves (see step 5) at the ends of the span to verify the correct position (Fig. 4.1). Also remember that the fins on the shelf should take no more than half the knuckle bore (Fig. 4.2). Now you can proceed with the remaining spans repeating steps 2, 3 and 4.

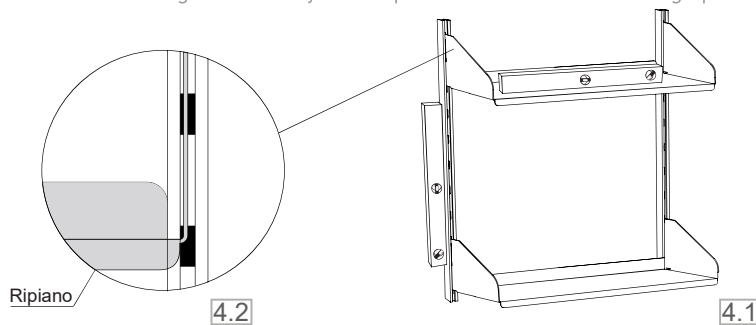

- 5** Ogni montante presenta, in basso, un foro laterale che serve a bloccare i montanti alla guida con la vite filettata, (5.1)  
 Inserire tutti i ripiani (5.2)
- Each upright is provided, at the bottom, a lateral hole which serves to lock the uprights to the guide with the screw threaded, (5.1). Place all shelves (5.2)

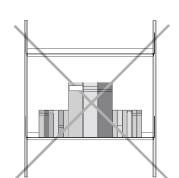
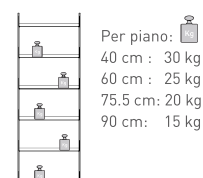
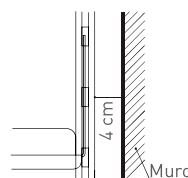
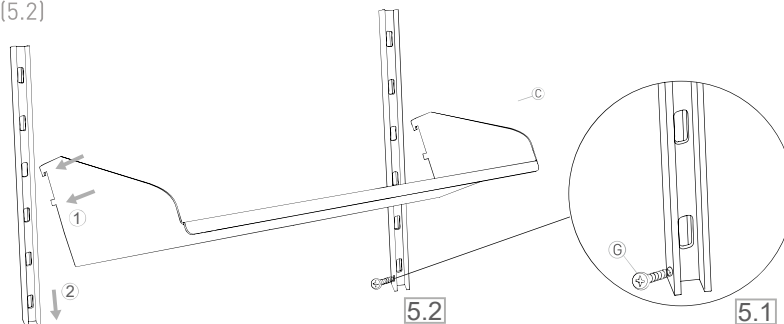

## COMPONENTI / COMPONENTS

A Montante Upright  
B Guid Support

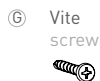
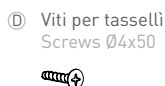
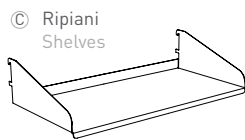

## COSA HAI BISOGNO / REQUIRED TOOLS

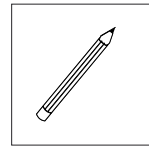
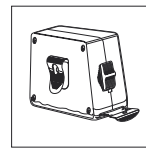
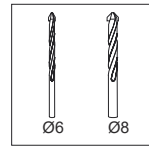
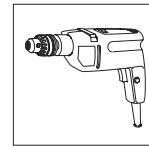
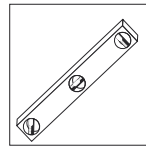

In presenza di pareti in cartongesso, si consiglia di utilizzare tasselli appositi.  
In case of plasterboard walls, we suggest you to use appropriate dowels.

- 1** Prima di procedere con il fissaggio dei montanti, bisogna verificare il corretto assetto del pavimento. In caso di dislivello compensare attraverso l'ausilio del piedino filettato "dislivello max. 1.5 cm".  
Before proceeding with fixing the uprights should be checked for correct positioning of the floor. In case of difference co in level mpensate through the leveling foot "drop max. 1.5 cm".

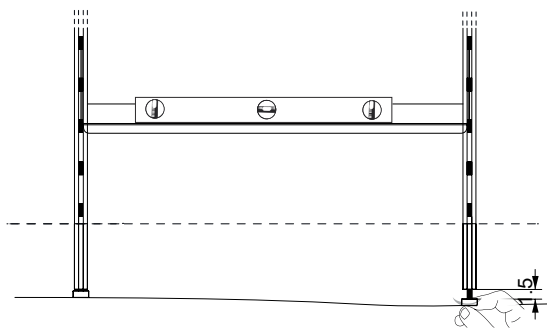

- 2** Individuare la posizione in cui si desidera montare la libreria (fig. 2.1). (Nel calcolo dell'ingombro totale bisogna considerare la larghezza dei ripiani (40/60/75.5/90 cm e la sporgenza dei due montanti esterni 1.5 cm cad.no). La distanza minima tra i montanti esterni e il bordo del muro, spigolo o angolo deve essere sempre di almeno 4 cm (fig. 2.2). Stabilita la posizione della libreria si procede con il montaggio di ogni singolo montante. Accostare il montante al muro e segnare con la matita un riferimento alla sommità del montante facendo attenzione che sia appoggiato al pavimento; quindi spostare il montante dal muro e segnare un secondo riferimento a 2.5 cm sotto il primo punto. Forare il secondo punto utilizzando prima la punta da Ø6 mm e successivamente quella da Ø8 mm, per allargare il foro (fig. 2.3).

Find the location where you want to install the bookcase (Figure 2.1). (In calculating the overall dimensions must consider the width of the shelves (40/60/75.5/90 cm and the ledge of the two outer uprights 1.5 cm each). The minimum distance between the uprights and the outer edge of the wall, edge or corner must always be at least 4 cm (Fig. 2.2). When you have decided on the bookcase's location, you proceed with the installation of every single upright. Push the upright on the wall and mark with a pencil a reference to the top of the upright, making sure that it is placed on the floor, then move the upright from the wall and mark with a pencil a second reference to 2.5 cm below the first point. Drill the second point first using the tip Ø6 mm and after the one from Ø8 mm, to enlarge the hole (fig. 2.3).

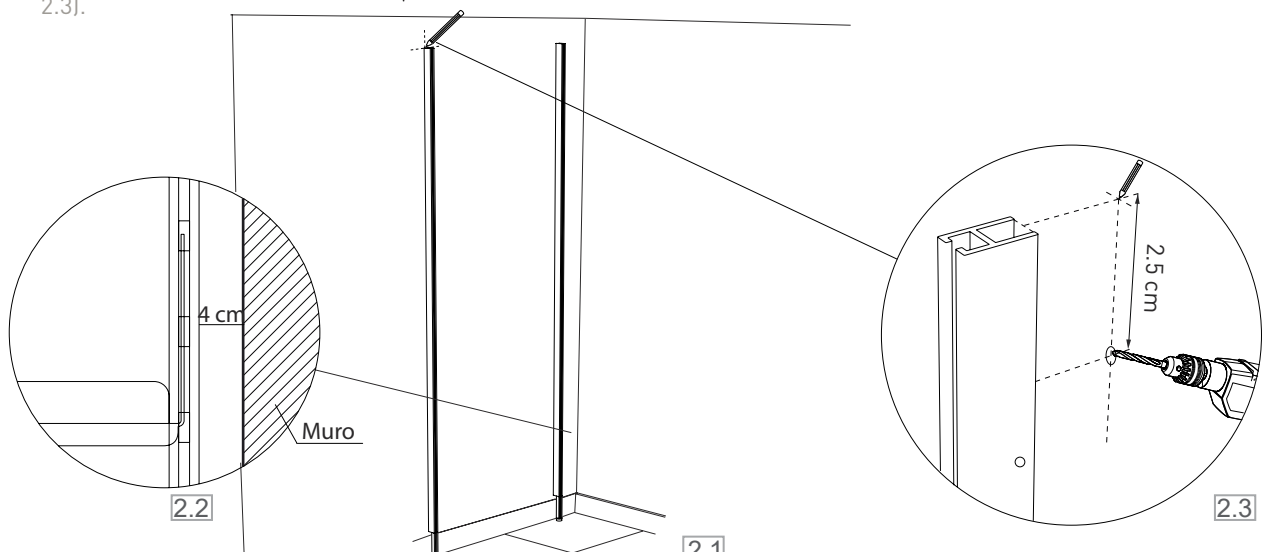

**3** Porre la dima in corrispondenza del primo foro (3.1) e segnare il successivo a 40, o 60, o 75.5, o 90 cm in base alla larghezza del ripiano, utilizzando la livella, verificare che i due fori siano allineati tra di loro.

Place the space bar in correspondence of the first hole (3.1) and the next mark to 40, or 60, or 75.5, or 90 cm based on the width of the shelf, using the level ensure that the two holes are aligned with each other.

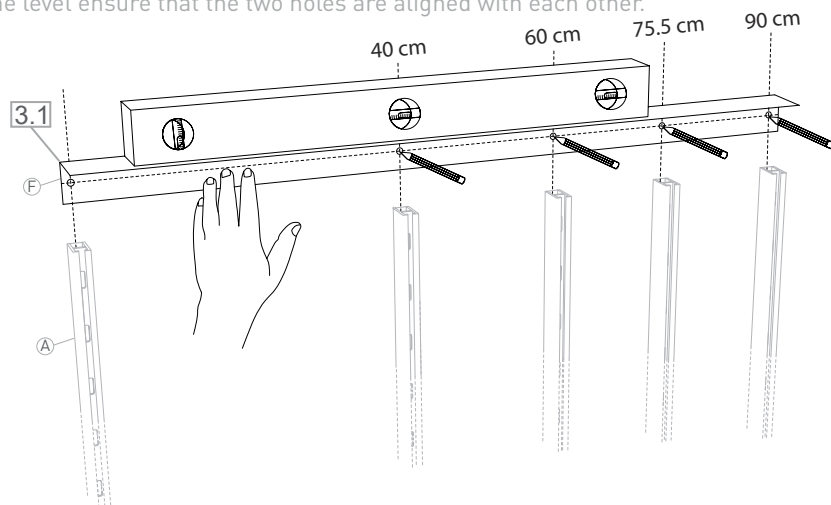

**4** Fissare la guida con vite e tassello in corrispondenza del primo foro, e segnare i riferimenti per quelli sottostanti (fig. 4.1).

Secure the rail with screws and dowels at the first hole, and mark the references to those below (4.1).

Forare i rimanenti fori ed inserire il tassello (fig. 4.2). Bloccare la guida con le viti in dotazione (fig. 4.3).

Drill the remaining holes and insert the dowel (4.2). Hold the guide with the supplied screws (4.3).

Terminato il fissaggio dei fori, Bloccare il montante alla guida con l'ausilio delle viti filettate (fig. 4.4).

Nel caso di pareti non a piombo utilizzare i distanziali per compensare i dislivelli.

Finished fixing holes, hook the mast to the guide (4.4). Use spacer rings in case of non perpendicular walls.

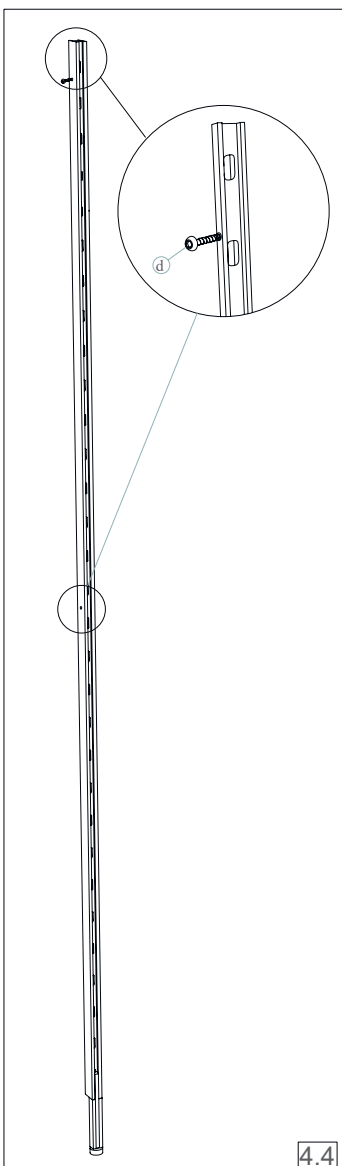
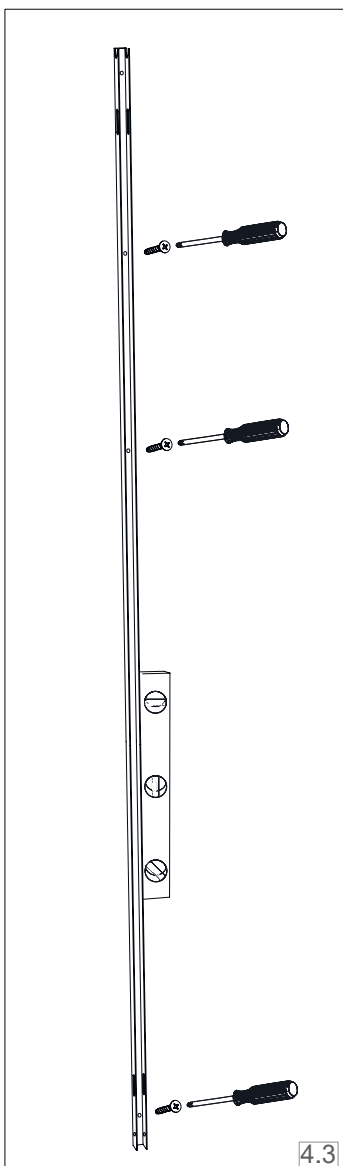
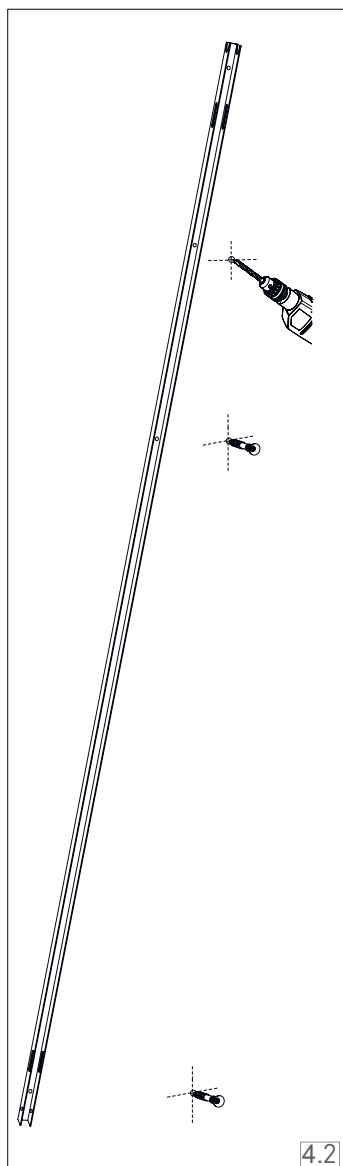
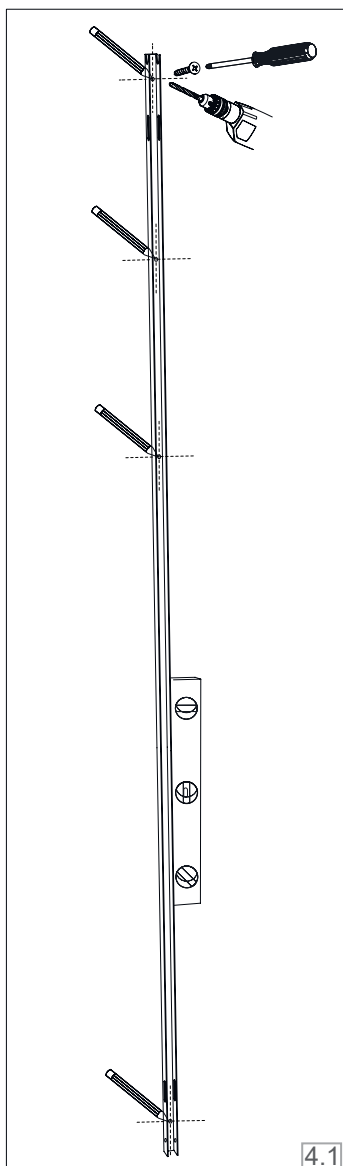

**5** Ripetere i passaggi 2, 3 e 4 per il fissaggio del secondo montante. Prima di procedere con il resto delle campate, inserire due ripiani (vedi passaggio 6) alle estremità della campata per verificarne il corretto assetto (fig. 5.1), "ricordiamo inoltre che le alette del ripiano dovranno occupare non oltre metà foro del montante, fig. 5.3". Regolare il piedino di ogni montante in modo da compensare eventuali dislivelli del pavimento (fig. 5.2). A questo punto sarà possibile procedere con le restanti campate ripetendo i passaggi 2, 3, 4 e 5. Ripetere la procedura per il resto delle campate.

Repeat steps 2 and 3 for fixing the second upright. Before proceeding with the rest of the bays, insert two shelves (see step 7) at the ends of the span to verify the correct position (Fig. 5.1). Also remember that the fins on the shelf should take no more than half the knuckle bore (Fig. 5.2). Now you can proceed with the remaining spans repeating steps 2, 3 and 4.

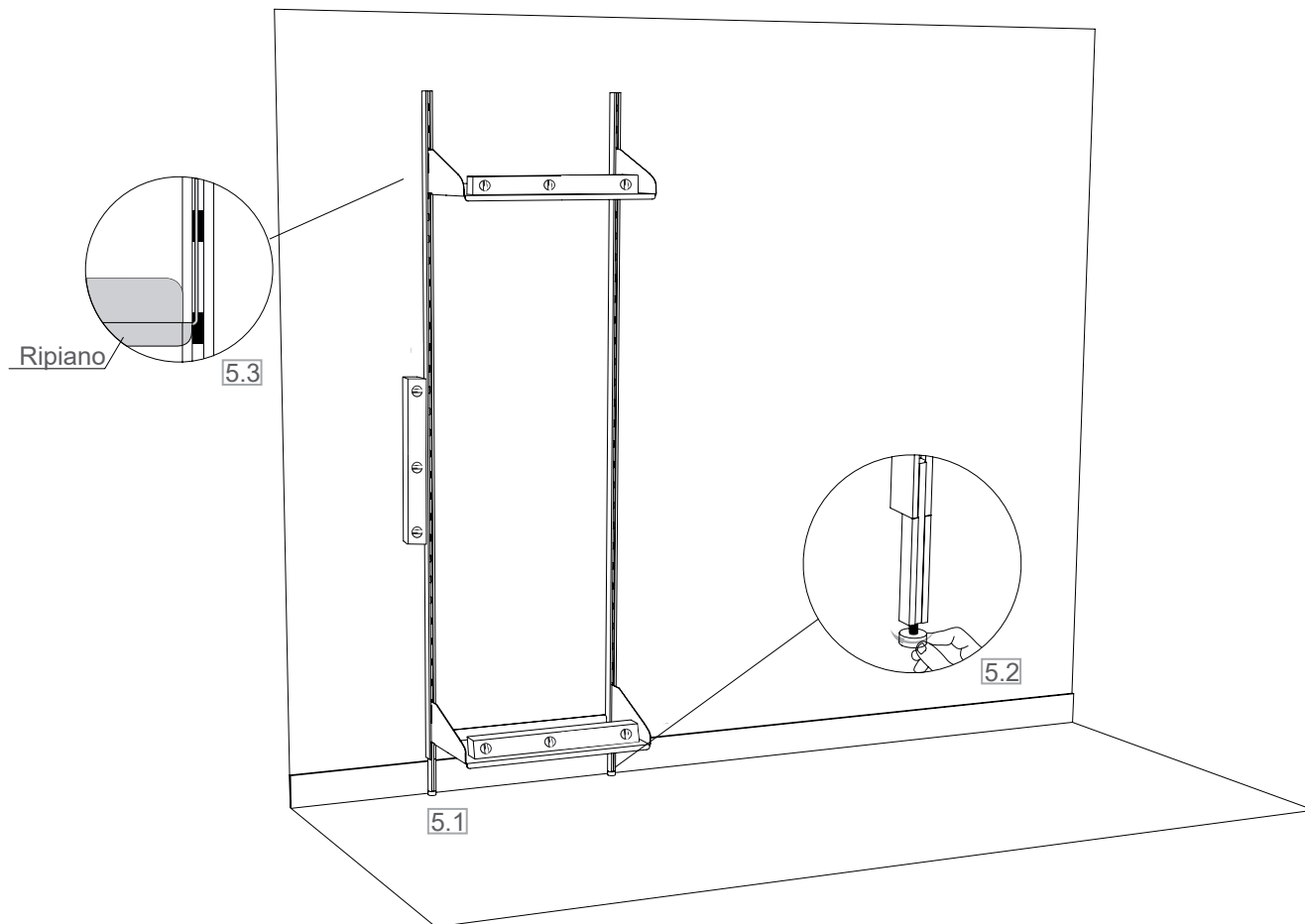

**6** Inserire i ripiani  
Place all shelves

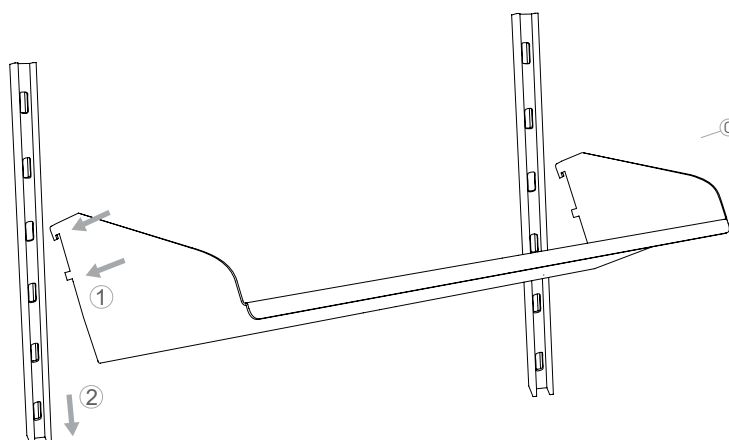

Panno umido, sapone neutro.  
Damp cloth, mild soap.

